

■ General Description

The AME1117 is a 1A low-dropout positive voltage regulator. It is available in fixed and adjustable output voltage versions. Overcurrent and thermal protection are integrated onto the chip. Output current will limit as while it reaches the pre-set current or temperature limit. The dropout voltage is specified at 1.4V Maximum at full rated output current. The AME1117 series provides excellent regulation over line, load and temperature variations.

■ Features

- Low dropout voltage ----- 1.4V at 1A
- Adjustable or fixed voltages: 1.8V, 2.5V, 3.3V, 5.0V
- Adjust pin current less than 120 μ A
- Overcurrent protection
- Thermal protection
- Available in TO-220, TO-252, SOT-223

■ Applications

- High Efficiency Linear Regulators
- Post Regulators for Switching Supplies
- 5V to 3.3V Voltage Converter
- Battery Charger

■ Functional Block Diagram

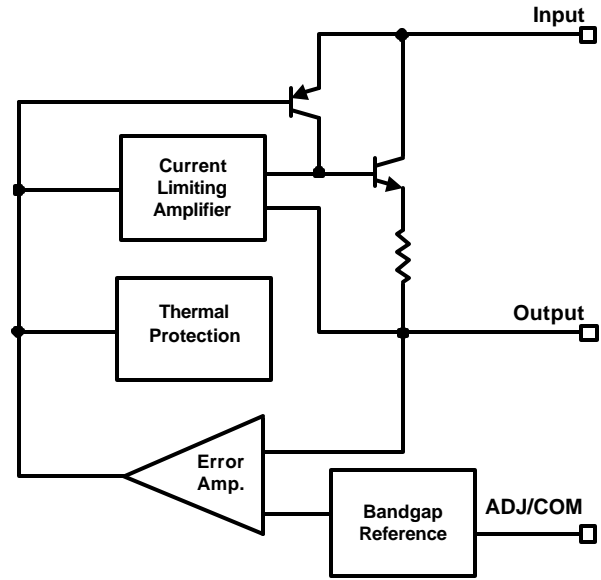

■ Typical Application

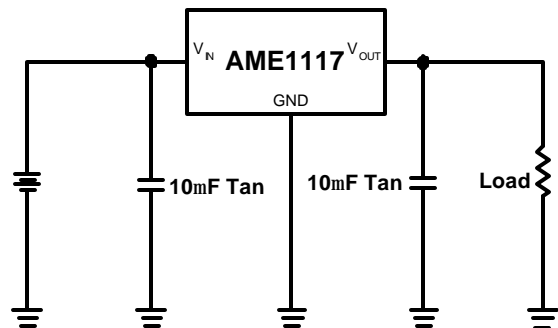



■ Pin Configuration

TO-220
Front View

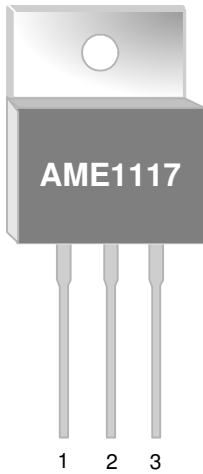

AME1117

1. ADJ/GND
2. V_{OUT} (TAB)
3. V_{IN}

* Die Attach:
Conductive Epoxy

SOT-223
Front View

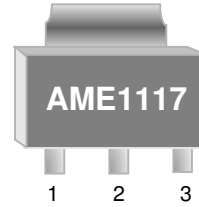

AME1117

1. ADJ/GND
2. V_{OUT} (TAB)
3. V_{IN}

* Die Attach:
Conductive Epoxy

TO-252
Front View

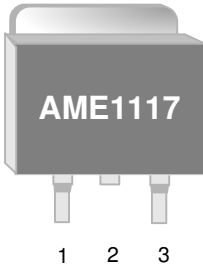

AME1117

1. ADJ/GND
2. V_{OUT} (TAB)
3. V_{IN}

* Die Attach:
Conductive Epoxy



AME1117

■ Ordering Information

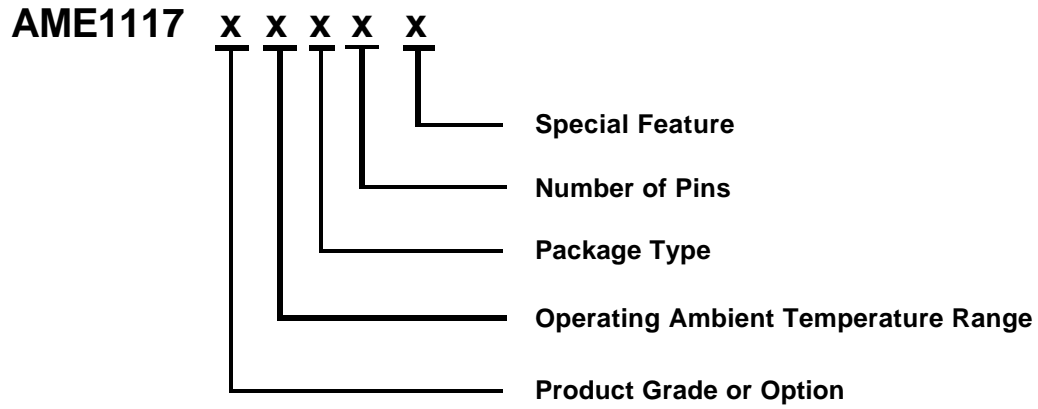

Product Grade or Option	Operating Ambient Temperature Range	Package Type	Number of Pins	Special Feature
A: ADJ B: 2.5V C: 3.3V D: 5.0V E: 1.8V	C: 0°C to 70°C	B: TO-220 C: TO-252 G: SOT-223	T: 3	Z: Lead Free



■ Ordering Information (contd.)

Part Number	Marking*	Output Voltage	Package	Operating Ambient Temperature Range
AME1117ACGT	ABEyw	ADJ	SOT-223	0°C to 70°C
AME1117ACGTZ	ABEyw	ADJ	SOT-223	0°C to 70°C
AME1117BCGT	AKEyw	2.5	SOT-223	0°C to 70°C
AME1117BCGTZ	AKEyw	2.5	SOT-223	0°C to 70°C
AME1117CCGT	ABFyw	3.3	SOT-223	0°C to 70°C
AME1117CCGTZ	ABFyw	3.3	SOT-223	0°C to 70°C
AME1117DCGT	AKFyw	5.0	SOT-223	0°C to 70°C
AME1117DCGTZ	AKFyw	5.0	SOT-223	0°C to 70°C
AME1117ECGT	AXHw	1.8	SOT-223	0°C to 70°C
AME1117ECGTZ	AXHw	1.8	SOT-223	0°C to 70°C
AME1117ACCT	AME1117 ACCT yyw	ADJ	TO-252	0°C to 70°C
AME1117ACCTZ	AME1117 ACCT yyw	ADJ	TO-252	0°C to 70°C
AME1117BCCT	AME1117 BCCT yyw	2.5	TO-252	0°C to 70°C
AME1117BCCTZ	AME1117 BCCT yyw	2.5	TO-252	0°C to 70°C
AME1117CCCT	AME1117 CCCT yyw	3.3	TO-252	0°C to 70°C
AME1117CCCTZ	AME1117 CCCT yyw	3.3	TO-252	0°C to 70°C
AME1117DCCT	AME1117 DCCT yyw	5.0	TO-252	0°C to 70°C
AME1117DCCTZ	AME1117 DCCT yyw	5.0	TO-252	0°C to 70°C



AME1117

■ Ordering Information

Part Number	Marking*	Output Voltage	Package	Operating Ambient Temperature Range
AME1117ECCT	AME1117 ECCT yyww	1.8	TO-252	0°C to 70°C
AME1117ECCTZ	AME1117 ECCT yyww	1.8	TO-252	0°C to 70°C
AME1117ACBT	AME1117 ACBT yyww	ADJ	TO-220	0°C to 70°C
AME1117ACBTZ	AME1117 ACBT yyww	ADJ	TO-220	0°C to 70°C
AME1117BCBT	AME1117 BCBT yyww	2.5	TO-220	0°C to 70°C
AME1117BCBTZ	AME1117 BCBT yyww	2.5	TO-220	0°C to 70°C
AME1117CCBT	AME1117 CCBT yyww	3.3	TO-220	0°C to 70°C
AME1117CCBTZ	AME1117 CCBT yyww	3.3	TO-220	0°C to 70°C
AME1117DCBT	AME1117 DCBT yyww	5.0	TO-220	0°C to 70°C
AME1117DCBTZ	AME1117 DCBT yyww	5.0	TO-220	0°C to 70°C
AME1117ECBT	AME1117 ECBT yyww	1.8	TO-220	0°C to 70°C
AME1117ECBTZ	AME1117 ECBT yyww	1.8	TO-220	0°C to 70°C

Note: yyww & yww represent the date code

* A line on top of the first letter represents lead free plating such as AME1117.

Please consult AME sales office or authorized Rep./Distributor for the availability of output voltage and package type.



■ Absolute Maximum Ratings

Parameter	Package	Die Attach	Symbol	Maximum	Unit
Thermal Resistance* (Junction to Case)	TO-220	Conductive Epoxy	θ_{JC}	6	$^{\circ}\text{C}/\text{W}$
	TO-252			5	
	SOT-223			25	
Thermal Resistance (Junction to Ambient)	TO-220		θ_{JA}	55	
	TO-252			90	
	SOT-223			120	
Internal Power Dissipation	TO-220		P_D	2200	mW
	TO-252			1200	
	TO-223			900	
Input Voltage			V_{IN}	12	V
Operating Junction Temperature			T_J	0 to 125	$^{\circ}\text{C}$
Storage Temperature Range			T_{STG}	- 65 to 150	
Lead Temperature (10 Sec)			T_{LEAD}	260	

* Measure θ_{JC} on backside center of tab.

Caution: Stress above the listed absolute maximum rating may cause permanent damage to the device.

AME1117
■ Electrical Specifications
AME1117Exxx

Parameter	Symbol	Test Condition	Min	Typ	Max	Units	
Output Voltage	V_{OUT}	$V_{IN} = 5V, I_O = 0A$	$T_J = 25^\circ C$	1.782	1.800	1.818	V
			$T_J = 0^\circ C \text{ to } 70^\circ C$	1.764	1.800	1.836	
Line Regulation	REG_{LINE}	$V_{IN} = 4.75V \text{ to } 7V,$ $I_O = 0A$	$T_J = 0^\circ C \text{ to } 70^\circ C$	-	-	0.2	%
Load Regulation	REG_{LOAD}	$V_{IN} = 5V,$ $I_O = 0A \sim 1A$	$T_J = 0^\circ C \text{ to } 70^\circ C$	-	0.1	1.0	
Dropout Voltage	$V_{DROPOUT}$	$I_O = 1A,$ $\Delta V_O = \pm 1\%$	$T_J = 0^\circ C \text{ to } 70^\circ C$	-	1.2	1.4	V
Current Limit	I_S	$V_{IN} = 4.75V \text{ to } 7V$	$T_J = 0^\circ C \text{ to } 70^\circ C$	1.0	1.5	-	A
Quiescent Current	I_Q	$V_{IN} = 5V, I_O = 0A \text{ to } 1A$	$T_J = 0^\circ C \text{ to } 70^\circ C$	-	6.0	13	mA
Temp. Coefficient	T_C	$V_{IN} = 4.75V \text{ to } 7V, I_O = 0A \text{ to } 1A$		-	0.005	-	%/ $^\circ C$
Temperature Stability	T_S	$V_{IN} = 5V, I_O = 100mA$	$T_J = 0^\circ C \text{ to } 70^\circ C$	-	0.5	-	%
RMS Output Noise	V_N	$10Hz \leq f \leq 10KHz$	$T_J = 25^\circ C$	-	0.003	-	% V_O
Ripple Rejection Ratio	R_A	$V_{IN} = 5V, I_O = 1A$	$T_J = 0^\circ C \text{ to } 70^\circ C$	60	72	-	dB

AME1117Dxxx

Parameter	Symbol	Test Condition	Min	Typ	Max	Units	
Output Voltage	V_{OUT}	$V_{IN} = 7V, I_O = 0A$	$T_J = 25^\circ C$	4.950	5.000	5.050	V
			$T_J = 0^\circ C \text{ to } 70^\circ C$	4.900	5.000	5.100	
Line Regulation	REG_{LINE}	$V_{IN} = 7V \text{ to } 9V,$ $I_O = 0A$	$T_J = 0^\circ C \text{ to } 70^\circ C$	-	-	0.2	%
Load Regulation	REG_{LOAD}	$V_{IN} = 7V$ $I_O = 0A \sim 1A$	$T_J = 0^\circ C \text{ to } 70^\circ C$	-	0.1	1.0	
Dropout Voltage	$V_{DROPOUT}$	$I_O = 0A \text{ to } 1A,$ $\Delta V_O = \pm 1\%$	$T_J = 0^\circ C \text{ to } 70^\circ C$	-	1.2	1.4	V
Current Limit	I_S	$V_{IN} = 7V \text{ to } 10V$	$T_J = 0^\circ C \text{ to } 70^\circ C$	1.0	1.5	-	A
Quiescent Current	I_Q	$V_{IN} = 7V, I_O = 0A \text{ to } 1A$	$T_J = 0^\circ C \text{ to } 70^\circ C$	-	6.0	13	mA
Temp. Coefficient	T_C	$V_{IN} = 7V \text{ to } 10V, I_O = 0A \text{ to } 1A$		-	0.005	-	%/ $^\circ C$
Temperature Stability	T_S	$V_{IN} = 5V, I_O = 100mA$	$T_J = 0^\circ C \text{ to } 70^\circ C$	-	0.5	-	%
RMS Output Noise	V_N	$10Hz \leq f \leq 10KHz$	$T_J = 25^\circ C$	-	0.003	-	% V_O
Ripple Rejection Ratio	R_A	$V_{IN} = 5V, I_O = 1A$	$T_J = 0^\circ C \text{ to } 70^\circ C$	60	72	-	dB

■ Electrical Specifications
AME1117Cxxx

Parameter	Symbol	Test Condition	Min	Typ	Max	Units	
Output Voltage	V_{OUT}	$V_{IN} = 5V, I_O = 0A$	$T_J = 25^\circ C$	3.270	3.300	3.330	V
			$T_J = 0^\circ C \text{ to } 70^\circ C$	3.234	3.300	3.366	
Line Regulation	REG_{LINE}	$V_{IN} = 4.75V \text{ to } 7V,$ $I_O = 0A$	$T_J = 0^\circ C \text{ to } 70^\circ C$	-	-	0.2	%
Load Regulation	REG_{LOAD}	$V_{IN} = 5V$ $I_O = 0A \text{ to } 1A$	$T_J = 0^\circ C \text{ to } 70^\circ C$	-	0.1	1.0	
Dropout Voltage	$V_{DROPOUT}$	$I_O = 0A \text{ to } 1A,$ $\Delta V_O = \pm 1\%$	$T_J = 0^\circ C \text{ to } 70^\circ C$	-	1.2	1.4	V
Current Limit	I_S	$V_{IN} = 4.75V \text{ to } 7V$	$T_J = 0^\circ C \text{ to } 70^\circ C$	1.0	1.5	-	A
Quiescent Current	I_Q	$V_{IN} = 5V, I_O = 0A \text{ to } 1A$	$T_J = 0^\circ C \text{ to } 70^\circ C$	-	6.0	13	mA
Temp. Coefficient	T_C	$V_{IN} = 4.75V \text{ to } 7V, I_O = 0A \sim 1A$		-	0.005	-	%/ $^\circ C$
Temperature Stability	T_S	$V_{IN} = 5V, I_O = 100mA$	$T_J = 0^\circ C \text{ to } 70^\circ C$	-	0.5	-	%
RMS Output Noise	V_N	$10Hz \leq f \leq 10KHz$	$T_J = 25^\circ C$	-	0.003	-	% V_O
Ripple Rejection Ratio	R_A	$V_{IN} = 5V, I_O = 1A$	$T_J = 0^\circ C \text{ to } 70^\circ C$	60	72	-	dB

AME1117Bxxx

Parameter	Symbol	Test Condition	Min	Typ	Max	Units	
Output Voltage	V_{OUT}	$V_{IN} = 5V, I_O = 0A$	$T_J = 25^\circ C$	2.475	2.500	2.525	V
			$T_J = 0^\circ C \text{ to } 70^\circ C$	2.450	2.500	2.550	
Line Regulation	REG_{LINE}	$V_{IN} = 4.75V \text{ to } 7V,$ $I_O = 0A$	$T_J = 0^\circ C \text{ to } 70^\circ C$	-	-	0.2	%
Load Regulation	REG_{LOAD}	$V_{IN} = 5V$ $I_O = 0A \text{ to } 1A$	$T_J = 0^\circ C \text{ to } 70^\circ C$	-	0.1	1.0	
Dropout Voltage	$V_{DROPOUT}$	$I_O = 0A \text{ to } 1A,$ $\Delta V_O = \pm 1\%$	$T_J = 0^\circ C \text{ to } 70^\circ C$	-	1.2	1.4	V
Current Limit	I_S	$V_{IN} = 4.75V \text{ to } 7V$	$T_J = 0^\circ C \text{ to } 70^\circ C$	1.0	1.5	-	A
Quiescent Current	I_Q	$V_{IN} = 5V, I_O = 0A \text{ to } 1A$	$T_J = 0^\circ C \text{ to } 70^\circ C$	-	6.0	13	mA
Temp. Coefficient	T_C	$V_{IN} = 4.75V \text{ to } 7V, I_O = 0A \sim 1A$		-	0.005	-	%/ $^\circ C$
Temperature Stability	T_S	$V_{IN} = 5V, I_O = 100mA$	$T_J = 0^\circ C \text{ to } 70^\circ C$	-	0.5	-	%
RMS Output Noise	V_N	$10Hz \leq f \leq 10KHz$	$T_J = 25^\circ C$	-	0.003	-	% V_O
Ripple Rejection Ratio	R_A	$V_{IN} = 5V, I_O = 1A$	$T_J = 0^\circ C \text{ to } 70^\circ C$	60	72	-	dB

AME1117

■ Electrical Specifications

AME1117Axxx

Parameter	Symbol	Test Condition	Min	Typ	Max	Units	
Reference Voltage	V_{REF}	$V_{IN} = 5V,$ $I_O = 10mA$	$T_J = 25^\circ C$	1.238	1.250	1.262	V
			$T_J = 0^\circ C \text{ to } 70^\circ C$	1.225	1.250	1.275	
Line Regulation *	REG_{LINE}	$V_{IN} = 4.75V \text{ to } 7V,$ $I_O = 10mA$	$T_J = 0^\circ C \text{ to } 70^\circ C$	-	-	0.2	%
Load Regulation	REG_{LOAD}	$V_{IN} = 5V,$ $I_O = 10mA \text{ to } 1A$	$T_J = 0^\circ C \text{ to } 70^\circ C$	-	0.1	1.0	
Dropout Voltage	$V_{DROPOUT}$	$I_O = 10mA \text{ to } 1A,$ $\Delta V_O = \pm 1\%$	$T_J = 0^\circ C \text{ to } 70^\circ C$	-	1.2	1.4	V
Current Limit	I_S	$V_{IN} = 2.7V \text{ to } 7V$	$T_J = 0^\circ C \text{ to } 70^\circ C$	1.0	1.5	-	A
Temp. Coefficient	T_C	$V_{IN} = 2.75V \text{ to } 7V, I_O = 10mA \text{ to } 1A$		-	0.005	-	%/°C
Adjust Pin Current	I_{ADJ}	$V_{IN} = 2.75V \text{ to } 7V,$ $I_O = 10mA \text{ to } 1A$	$T_J = 0^\circ C \text{ to } 70^\circ C$	-	55	120	μA
Adjust Pin Current Change	ΔI_{ADJ}	$V_{IN} = 2.75V \text{ to } 7V,$ $I_O = 10mA \text{ to } 1A$	$T_J = 0^\circ C \text{ to } 70^\circ C$	-	0.2	5.0	
Temperature Stability	T_S	$V_{IN} = 5V, I_O = 100mA$	$T_J = 0^\circ C \text{ to } 70^\circ C$	-	0.5		%
Minimum Load Current	I_O	$V_{IN} = 5V$		-	5.0	10	mA
RMS Output Noise	V_N	$10Hz \leq f \leq 10KHz$	$T_J = 25^\circ C$	-	0.003	-	% V_O
Ripple Rejection Ratio	R_A	$V_{IN} = 5V, I_O = 1A$	$T_J = 0^\circ C \text{ to } 70^\circ C$	60	72	-	dB

*Line regulation test circuit

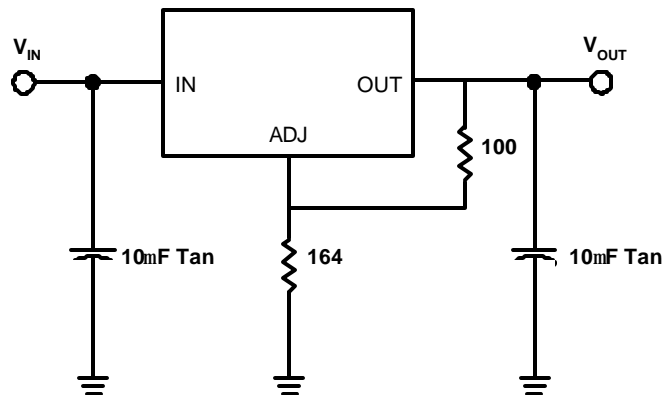

■ Application Description

1. Output voltage adjustment

Like most regulators, the AME1117 regulates the output by comparing the output voltage to an internally generated reference voltage. On the adjustable version, the V_{REF} is available externally as 1.25V between V_{OUT} and ADJ. The voltage ratio formed by R1 and R2 should be set to conduct 10mA (minimum output load). The output voltage is given by the following equation:

$$V_{OUT} = V_{REF} \left(1 + \frac{R2}{R1} \right) + I_{ADJ} \times R2$$

On fixed versions of AME1117, the voltage divider is provided internally.

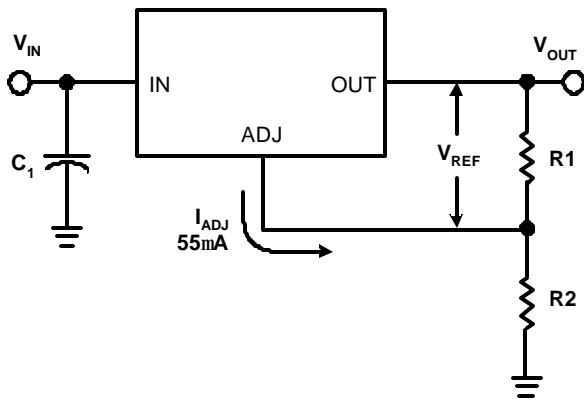

$$V_{OUT} = V_{REF} \left(1 + \frac{R2}{R1} \right) + I_{ADJ} \times R2$$

2. Thermal protection

AME1117 has thermal protection which limits junction temperature to 150°C. However, device functionality is only guaranteed to a maximum junction temperature of +125°C.

The power dissipation and junction temperature for AME1117 is given by

$$P_D = (V_{IN} - V_{OUT}) \times I_{OUT}$$

$$T_{JUNCTION} = T_{AMBIENT} + (P_D \times \theta_{JA})$$

Note: $T_{JUNCTION}$ must not exceed 125°C

3. Current limit protection

AME1117 is protected against overload conditions. Current protection is triggered at typically 1.5A.

4. Stability and load regulation

AME1117 requires a capacitor from V_{OUT} to GND to provide compensation feedback to the internal gain stage. This is to ensure stability at the output terminal. Typically, a 10µF tantalum or 50µF aluminum electrolytic is sufficient.

(Note: It is important that the ESR for this capacitor does not exceed 0.5W.)

The output capacitor does not have a theoretical upper limit and increasing its value will increase stability. $C_{OUT} = 100\mu\text{F}$ or more is typical for high current regulator design.

For the adjustable version, the best load regulation is accomplished when the top of the resistor divider (R1) is connected directly to the output pin of the AME1117. When so connected, R_p is not multiplied by the divider ratio.

For fixed output versions, the top of R1 is internally connected to the output. The ground pin can be connected to the low side of the load in order to eliminate ground loop errors.

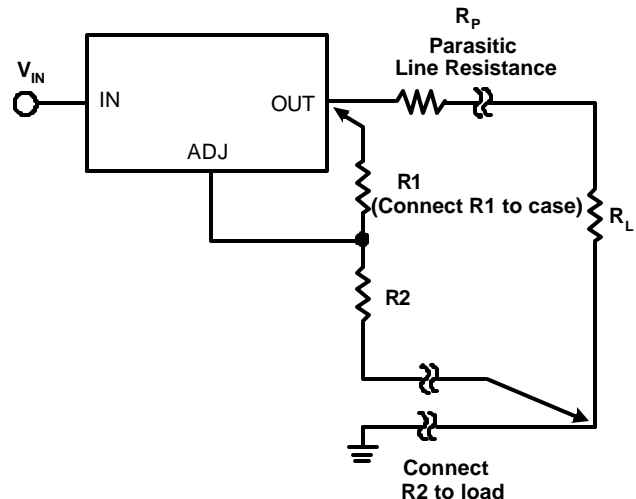



AME1117

5. Thermal consideration

The AME1117 series contain thermal limiting circuitry designed to protect itself from over-temperature conditions. Even for normal load conditions, maximum junction temperature ratings must not be exceeded. As mentioned in thermal protection section, we need to consider all sources of thermal resistance between junction and ambient. It includes junction-to-case, case-to-heat-sink interface and heat sink thermal resistance itself.

Junction-to-case thermal resistance is specified from the IC junction to the bottom of the case directly below the die. Proper mounting is required to ensure the best possible thermal flow from this area of the package to the heat sink. The case of all devices in this product series is electrically connected to the output. Therefore, if the case of the device must be electrically isolated, a thermally conductive spacer is recommended.



■ Advanced Applications

Adjustable Output Voltage

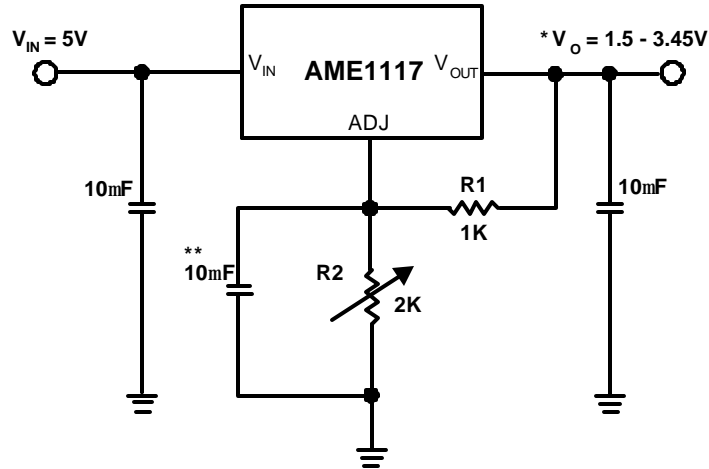

Note: $* V_{OUT} = V_{REF} \left(1 + \frac{R2}{R1} \right) + I_{ADJ} \times R2$

** Optional for improved ripple rejection

Paralleling Regulators

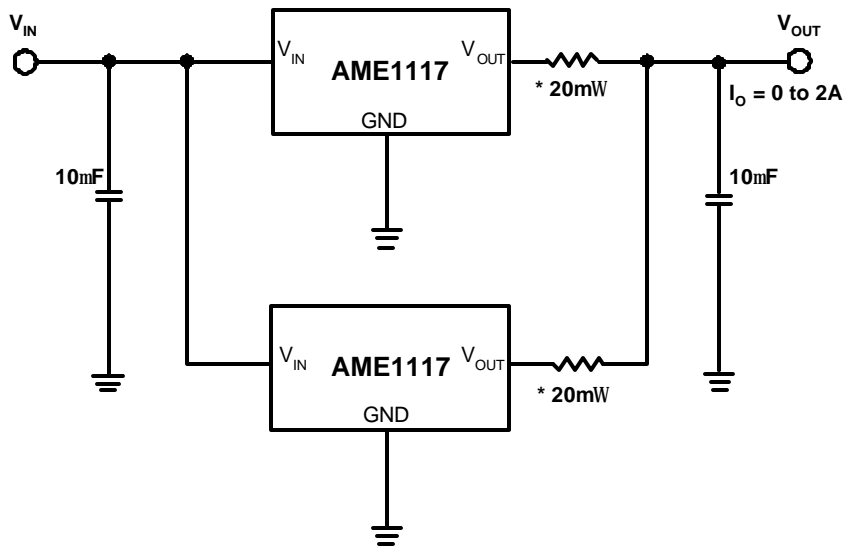

Note: * 20mΩ is ballast resistance
The inter - connection of #18 wire could act as ballast resistance

AME1117

■ Advanced Applications (contd.)

Regulator with Reference

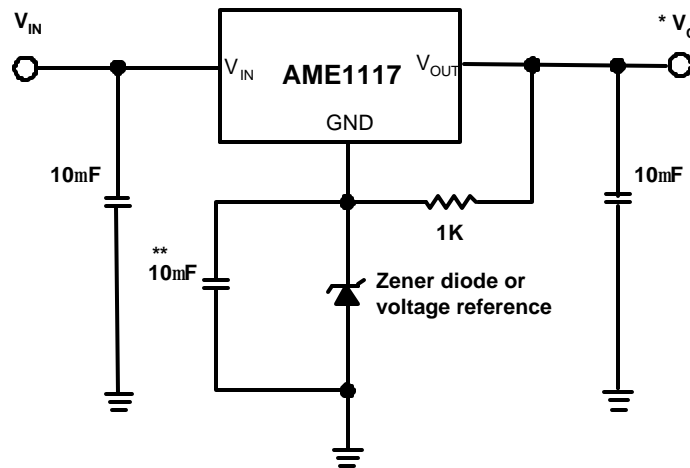

Note: * $V_o = V_{REF} + V_z$ (V_z : breakdown voltage of Zener diode)
 ** Optional for improved ripple rejection

Regulator with Reverse Diode Protection

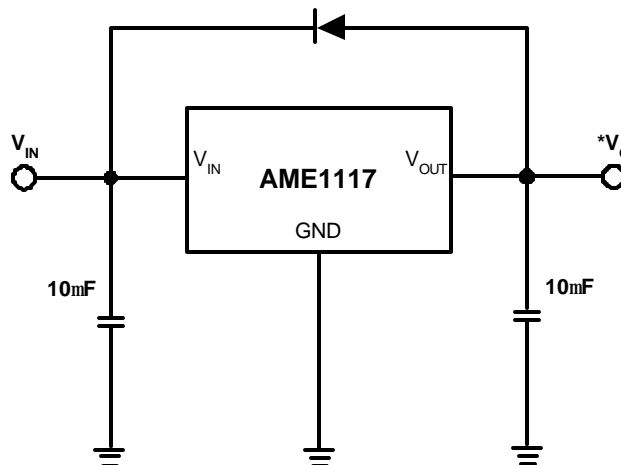



Temperature Stability (For Fixed Voltage)

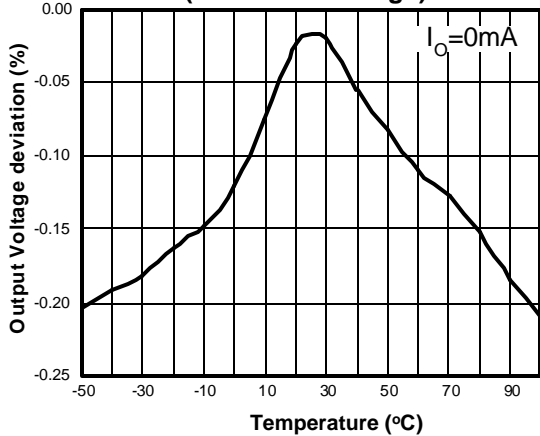

Temperature Stability (For Adjustable Voltage)

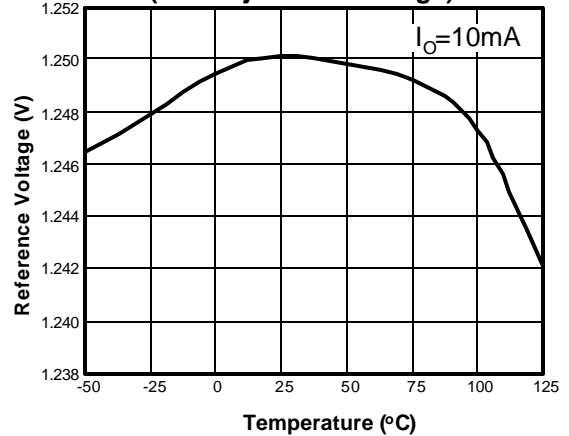

Short Circuit Current

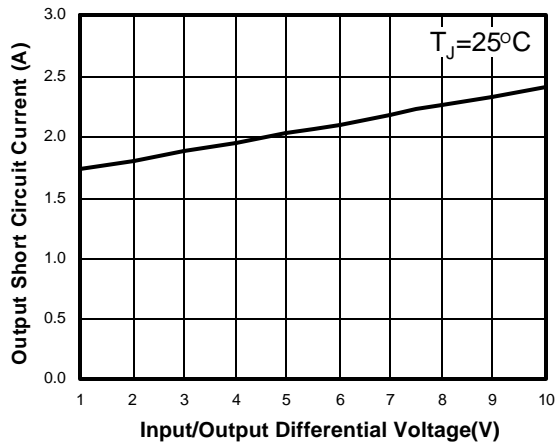

Dropout Voltage

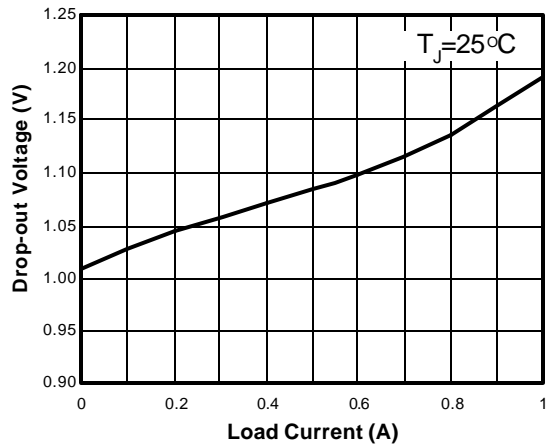

Adjust Pin Current

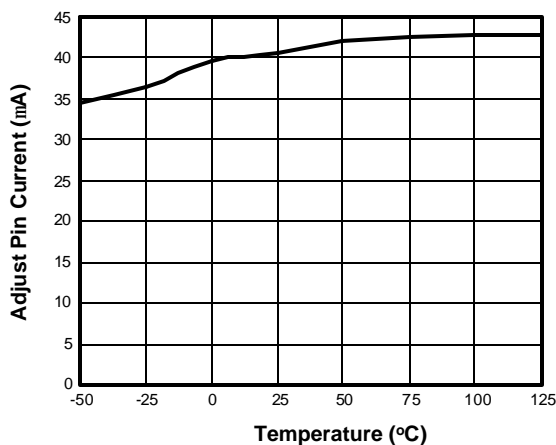

Minimum Operating Current

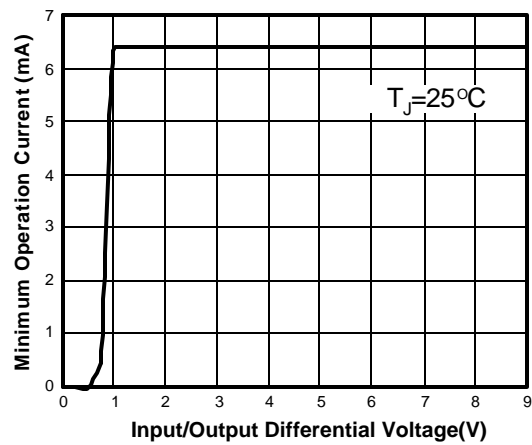



Load Transient Response

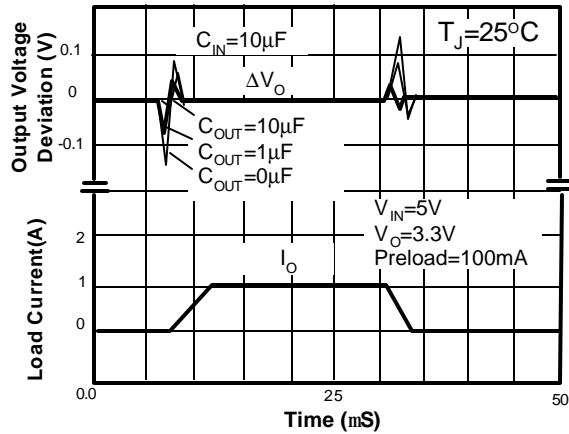

Line Transient Response

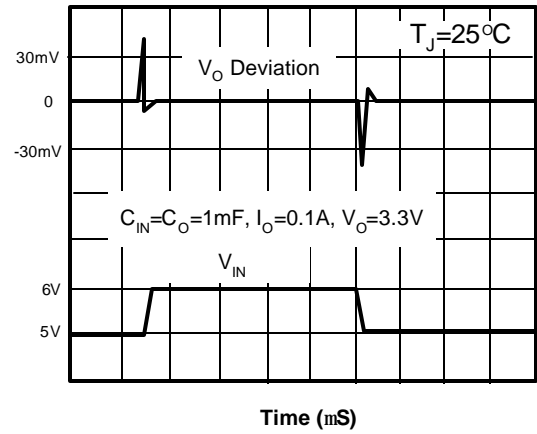

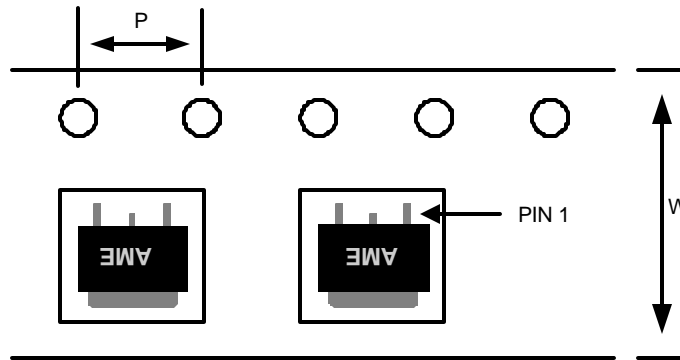
AME1117
■ Tape and Reel Dimension
TO-252

Carrier Tape, Number of Components Per Reel and Reel Size

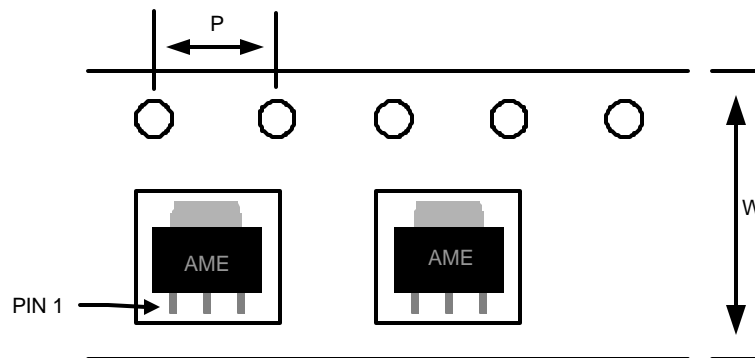
Package	Carrier Width (W)	Pitch (P)	Part Per Full Reel	Reel Size
TO-252	16.0±0.1 mm	4.0±0.1 mm	2500pcs	330±1 mm

SOT-223

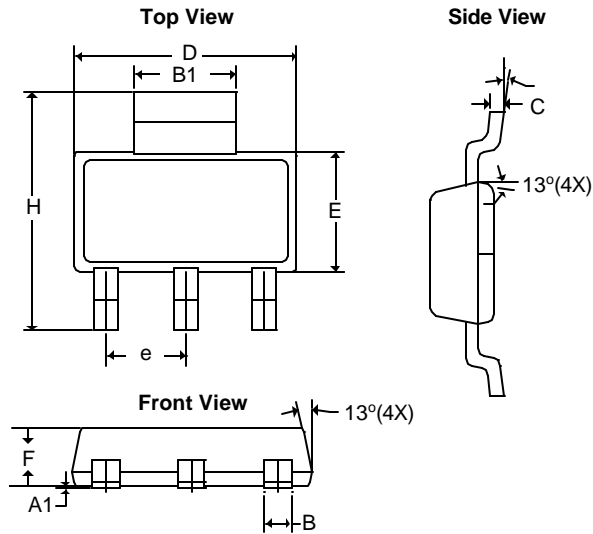
Carrier Tape, Number of Components Per Reel and Reel Size

Package	Carrier Width (W)	Pitch (P)	Part Per Full Reel	Reel Size
SOT-223	12.0±0.1 mm	4.0±0.1 mm	2500pcs	330±1 mm

■ Package Dimension
SOT-223

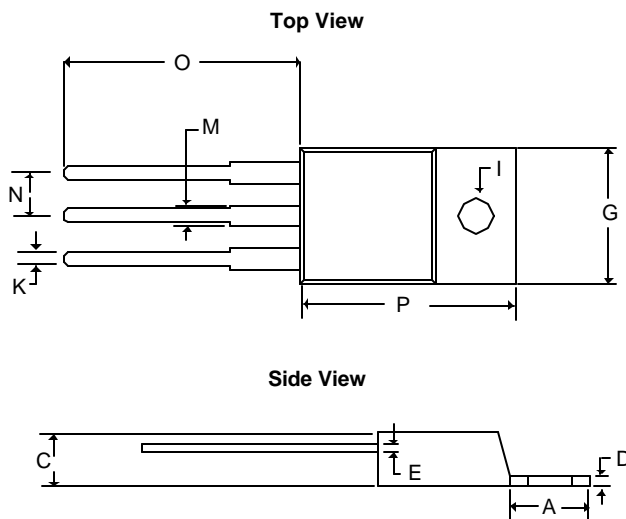
SYMBOLS	MILLIMETERS		INCHES	
	MIN	MAX	MIN	MAX
A ₁	0.01	0.10	0.0004	0.0039
B	0.60	0.84	0.0236	0.0330
B ₁	2.90	3.15	0.1140	0.1240
C	0.24	0.38	0.0094	0.0150
D	6.30	6.71	0.2480	0.2640
E	3.30	3.71	0.1299	0.1460
F	1.40	1.80	0.0551	0.0709
e	2.30 BSC		0.0906 BSC	
H	6.70	7.30	0.2638	0.2874
q	0°	10°	0°	10°

TO-220

SYMBOLS	MILLIMETERS		INCHES	
	MIN	MAX	MIN	MAX
A	5.58	7.49	0.2197	0.2949
C	2.03	4.83	0.0800	0.1902
D	0.50	1.40	0.0197	0.0550
E	0.30	1.15	0.0118	0.0453
G	9.65	10.67	0.3799	0.4200
I	3.53	4.09	0.1390	0.1610
K	0.50	1.15	0.0197	0.0453
M	1.14	1.78	0.0449	0.0700
N	2.28	2.80	0.0898	0.1102
O	12.70	14.74	0.5000	0.5803
P	14.22	16.51	0.5600	0.6500

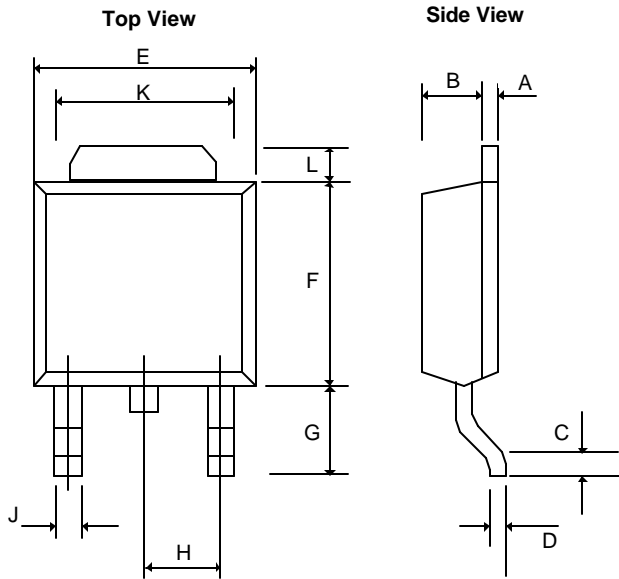
■ Package Dimension
TO-252-EIAJ

SYMBOLS	MILLIMETERS		INCHES	
	MIN	MAX	MIN	MAX
A	0.43	0.58	0.0169	0.0230
B	1.60	1.95	0.0630	0.0768
C	0.51	1.78	0.0200	0.0701
D	0.43	0.60	0.0169	0.0236
E	6.35	6.80	0.2500	0.2677
F	5.36	7.20	0.2110	0.2835
G	2.20	3.00	0.0866	0.1181
H	-	* 2.30	-	*0.0906
J	-	0.97	-	0.0380
K	5.20	5.50	0.2047	0.2165
L	1.40REF		0.055REF	

***: Typical Value**

Notes:

1. Controlling dimension: Millimeters.
2. Maximum lead thickness includes lead finish thickness. Minimum lead thickness is the minimum thickness of base material.



www.ame.com.tw
E-Mail: sales@ame.com.tw

Life Support Policy:

These products of AME, Inc. are not authorized for use as critical components in life-support devices or systems, without the express written approval of the president of AME, Inc.

AME, Inc. reserves the right to make changes in the circuitry and specifications of its devices and advises its customers to obtain the latest version of relevant information.

© AME, Inc. , August 2006

Document: 1014-DS1117-R.01

Corporate Headquarter
AME, Inc.

2F, 302 Rui-Guang Road, Nei-Hu District
Taipei 114, Taiwan.
Tel: 886 2 2627-8687
Fax: 886 2 2659-2989

U.S.A.(Subsidiary)
Analog Microelectronics, Inc.

3100 De La Cruz Blvd., Suite 201
Santa Clara, CA. 95054-2046
Tel : (408) 988-2388
Fax: (408) 988-2489